

BAROMETER MODULE

2006-1-3

- . Integrated pressure sensor
- . Pressure Range 300-1100hpa
- . 15 Bit Σ - Δ ADC
- . 7 coefficients for software compensation stored on chip
- . I²C Serial Interface
- . One system clock line (32768Hz)
- . One hardware controlled reset line
- . Low voltage, low power

Description

The RPPS01A-2 includes a piezo-resistive pressure sensor and an ADC interface. It provides 16 bit word data for pressure and temperature related voltage. With the help of a highly accurate calibration of the sensor, 10 unique coefficients were stored on the chip, thus accurate pressure and temperature reading can be realized. RPPS01A-2 is a low power, low voltage device with automatic power down switching. I²C Serial Interface is used for communications with a microprocessor. Sensor packaging options are DIP or SMD (with metal cap)

Features

- . 15 Bit ADC resolution
- . Supply voltage 2.2v-3.6v
- . -40°C to + 125°C operating range

Applications

- . Pressure measurement and control systems
- . Mobile altimeter/barometer systems
- . Weather forecast products
- . Adventure or multi-mode watches

Block Diagram

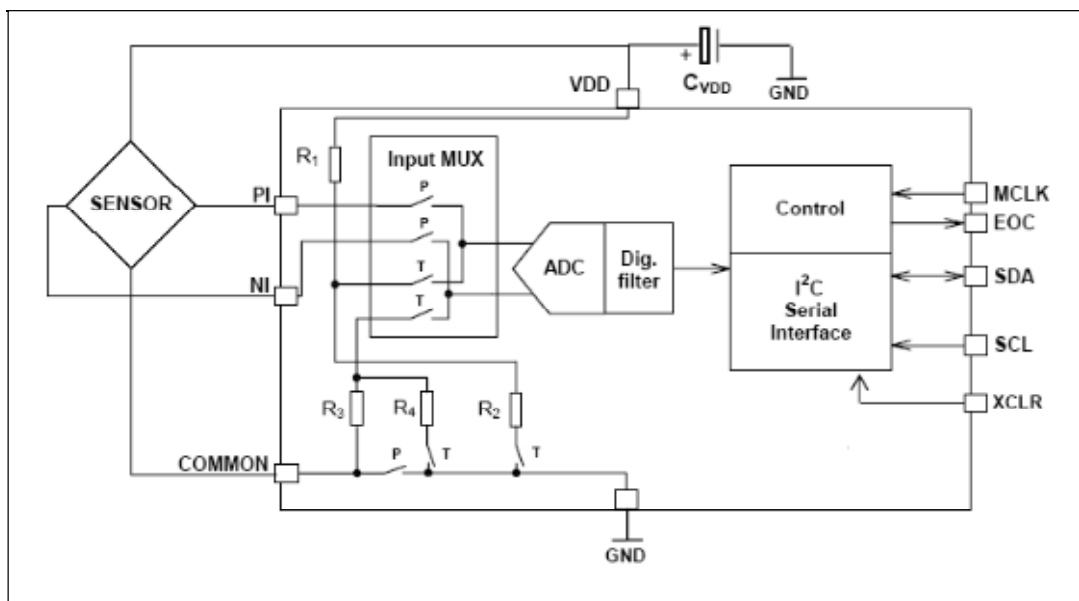

BAROMETER MODULE

2006-1-3

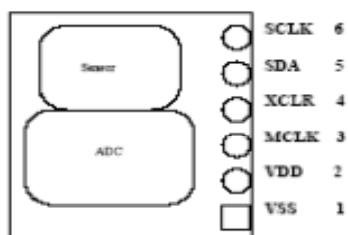

| Pin Name | Pin Number | Type | Function |
|----------|------------|------|--|
| VSS | 1 | G | power ground |
| VDD | 2 | P | power VCC |
| MCLK | 3 | I | master clock (32k) input |
| XCLR | 4 | I | ADC reset input |
| SDA | 5 | I/O | I ² C data input and output |
| SCL | 6 | I | I ² C clock input |

* XCLR is to reset the AD converter (active low), before start to operate the device, pull low XCLR pin to reset the AD. During the AD conversion phase, XCLR should stay high.

Absolute Maximum Ratings

| Parameter | Symbol | Min | Max | Unit |
|---------------------|--------|------|-----|-----------|
| Supply Voltage | VDD | -0.3 | 4 | V |
| Over pressure | P | | 15 | Bar (abs) |
| Storage Temperature | Tstg | -20 | 70 | °C |

Recommended Operating Conditions

| Parameter | Symbol | Conditions | Min | Typ | Max | Unit |
|-----------------------------|--------|------------|-----|-----|------|-----------|
| Supply Voltage | VDD | | 2.2 | 3 | 3.6 | V |
| Supply Current | I | VDD=3V | | | | V |
| during conversion | | | | 500 | | μA |
| stand by | | | | 2 | | μA |
| Operating Pressure Range | P | | 300 | | 1100 | hpa (abs) |
| Operating Temperature Range | T | | -40 | 25 | 125 | °C |
| Conversion Time | T | MCLK=32k | | | 35 | ms |
| Duty Cycle of MCLK | | | 40% | 50% | 60% | % |
| Serial Date Rate | SCL | | | | 500 | KHZ |

BAROMETER MODULE

2006-1-3

Pressure and Temperature Output Characteristics

With the calibration data provided by the RPPS01A-2 system, it should be able to reach the following characteristics:

| Parameter | Symbol | Conditions | Min | Typ | Max | Unit |
|--------------------------------|--------|------------|------|-----|-----|------|
| Resolution | | | 0.1 | | | hpa |
| Accuracy | | 750-1100 | -0.5 | | 0.5 | hpa |
| Absolute Pressure Accuracy | | 750-1100 | -1.5 | | 1.5 | hpa |
| Maximum Error Over Temperature | | -40~+125 | -1 | | 1 | hpa |
| Long Term Stability | | 6 months | | 2 | | hpa |
| VDD Dependency | | 2.2~3.6 | -1.5 | 0 | 1.5 | hpa |
| Temperature Accuracy | | | -0.8 | | 0.8 | °C |

Pressure and Temperature Measurement

The main function of RPPS01A-2 system is to convert the uncompensated pressure and temperature signal from a pressure sensor. After the conversion, the following two values can be obtained:

- . measured temperature “D2”
- . measured pressure “D1”

As the sensor is strongly temperature dependent, it is necessary to compensate for these effects. Therefore 10 sensor-specific coefficients are stored on the RPPS01A-2 at our manufacturing facility, and they allow accurate software compensation in the application.

The 7 coefficients are:

- . Sensitivity coefficient “C1”
- . Offset coefficient “C2”
- . Temperature Coefficient of Sensitivity “C3”
- . Temperature Coefficient of Offset “C4”
- . Reference Temperature “C5”
- . Temperature Coefficient of Temperature “C6”
- . Offset Fine Tuning “C7”
- . Sensor Specific Parameter “A,B,C,D”

Pressure and Temperature Calculation:

Step 1: (get temperature value)

| |
|--|
| $D2 \geq C5 \quad dUT = D2 - C5 - ((D2 - C5) / 2^7) * ((D2 - C5) / 2^7) * A / 2^C$ $D2 < C5 \quad dUT = D2 - C5 - ((D2 - C5) / 2^7) * ((D2 - C5) / 2^7) * B / 2^C$ |
|--|

BAROMETER MODULE

2006-1-3

Step 2: (calculate offset, sensitivity and final pressure value)

$$\text{OFF} = (C2 + (C4 - 1024) * dUT / 2^{14}) * 4$$

$$\text{SENS} = C1 + C3 * dUT / 2^{10}$$

$$X = \text{SENS} * (D1 - 7168) / 2^{14} - \text{OFF}$$

$$P = X * 10 / 2^5 + C7$$

- For altitude measurement system, recommend to use $P = X * 100 / 2^5 + C7 * 10$
- So that better altitude resolution can be achieved

Step 3: (calculate temperature)

$$T = 250 + dUT * C6 / 2^{16} - dUT / 2^D$$

Example:

C1=29908

C2=3724

C3=312

C4=441

C5=9191

C6=3990

C7=2500

A=1

B=4

C=4

D=9

D1=30036

D2=4107

dUT = -5478

OFF = 15675

SENS= 28238

X= 23738

P= 9918= 991.8hpa

T= -74 = -7.4 °C

Serial Interface

The I2C interface is used for accessing calibration data as well as reading measurement result from AD conversion.

BAROMETER MODULE

2006-1-3

The RPPS01A-2 system has a 2k bits (256*8) EEPROM built in, and the space in the range of 16 to 127 were dedicated for calibration coefficients and factory testing use only, while space between 128 to 255 can be used for user definable data storage purpose. **It is the user's responsibility to make sure that data in range of 16 to 127 will not be changed. Any accidental corruption to those data will lead to system failure and can lead to wrong calculated pressure and temperature results.**

The EEPROM chip address is set to 0, and reading or writing of the EEPROM is fully compatible to AT24C02. Bus drive timing should be referred to the specification of this part as well.

| Coefficient | EEPROM ADDRESS |
|-------------|----------------|
| C1(MSB:LSB) | (16:17) |
| C2(MSB:LSB) | (18:19) |
| C3(MSB:LSB) | (20:21) |
| C4(MSB:LSB) | (22:23) |
| C5(MSB:LSB) | (24:25) |
| C6(MSB:LSB) | (26:27) |
| C7(MSB:LSB) | (28:29) |
| A | (30) |
| B | (31) |
| C | (32) |
| D | (33) |

Pressure Measure:

| | | | | | | | | | | | | | | | | | | | |
|---|----------|----------|----------|----------|----------|---|---|---|----------|----------|----------|---|----------|----------|------------|----------|------------|---|---|
| S | 11101110 | A | 11111111 | A | 11110000 | P | D | S | 11101110 | A | 11111101 | S | 11011111 | A | MSB | A | LSB | N | P |
|---|----------|----------|----------|----------|----------|---|---|---|----------|----------|----------|---|----------|----------|------------|----------|------------|---|---|

Temperature Measure:

| | | | | | | | | | | | | | | | | | | | |
|---|----------|----------|----------|----------|----------|---|---|---|----------|----------|----------|---|----------|----------|------------|----------|------------|---|---|
| S | 11101110 | A | 11111111 | A | 11101000 | P | D | S | 11101110 | A | 11111101 | S | 11011111 | A | MSB | A | LSB | N | P |
|---|----------|----------|----------|----------|----------|---|---|---|----------|----------|----------|---|----------|----------|------------|----------|------------|---|---|

S: start bit

P: stop bit

A (bold): acknowledge from slave

A: acknowledge from master

N: not acknowledge from master (send out bit 1 instead)

D: delay for 40ms minimum

MSB: conversion result MSB

LSB: conversion result LSB.

Remark: before start an AD conversion cycle, remember to use XCLR pin to reset the AD converter.

BAROMETER MODULE

2006-1-3

Typical Application Circuit Diagram:

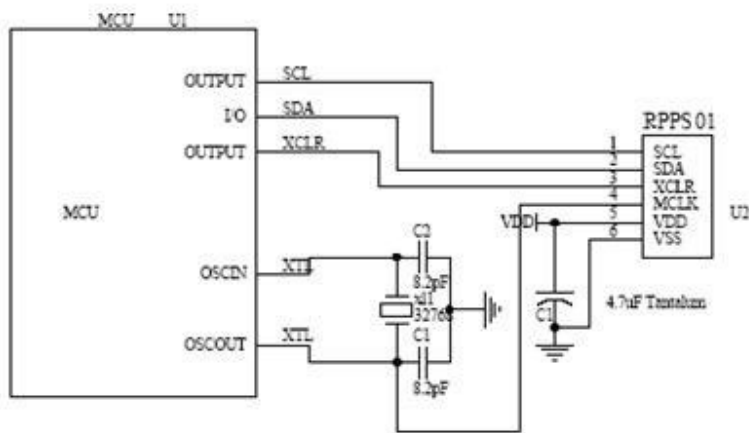

RPPS01A-2 Mechanical Dimension

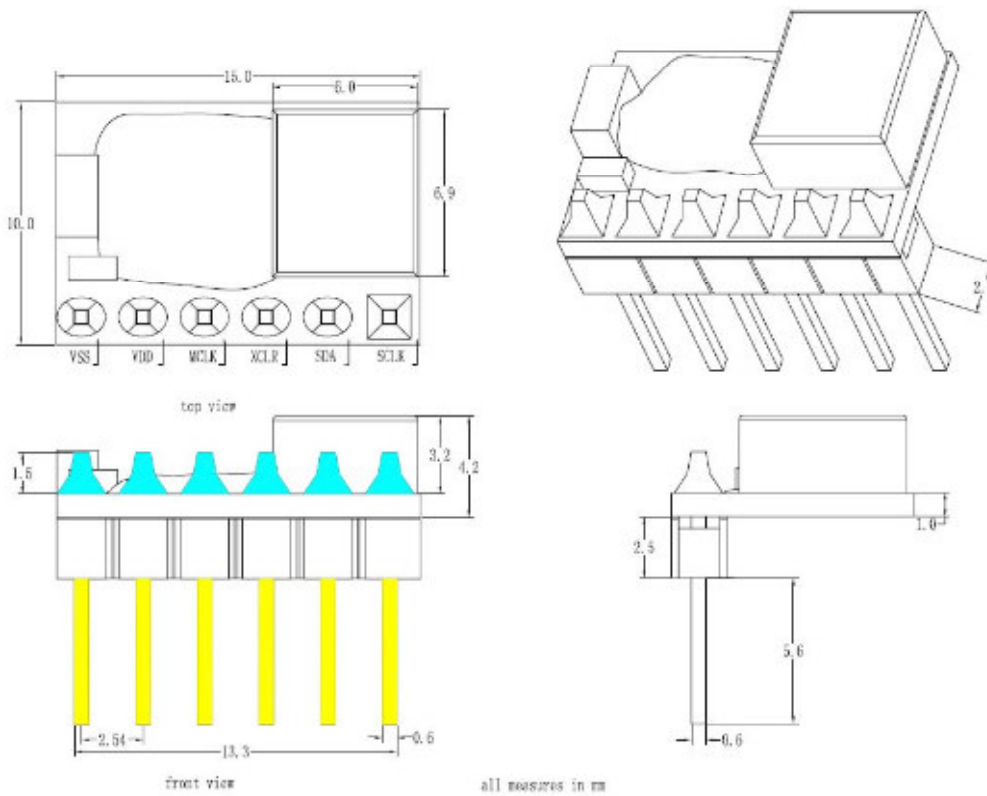

BAROMETER MODULE

2006-1-3

Important Notices

Do not use this product as safety or emergency stop device or in any application where failure of this product could lead in personal injury. Failure to comply with these instructions could result with death or serious injury.

Should buyer purchase or use SENSLED products for any such unintended or unauthorized application, buyer should indemnify and hold SENSLED and its officers, employees, affiliates and distributors harmless against all claims, costs, damages and expenses, and reasonable attorney fees arising out of, directly or indirectly, any claim of personal injury associated with such unintended or unauthorized use, even if such claim alleges that SENSLED was negligent regarding the design or manufacturing of the part.

SENSLED reserves the right, without further notice, to change the product specification and/or information in this document and to improve reliability, functions and design.